

O. ALLEN.
SPOKE-POLISHING MACHINES.

No. 195,555.

Patented Sept. 25, 1877.

Fig. 1.

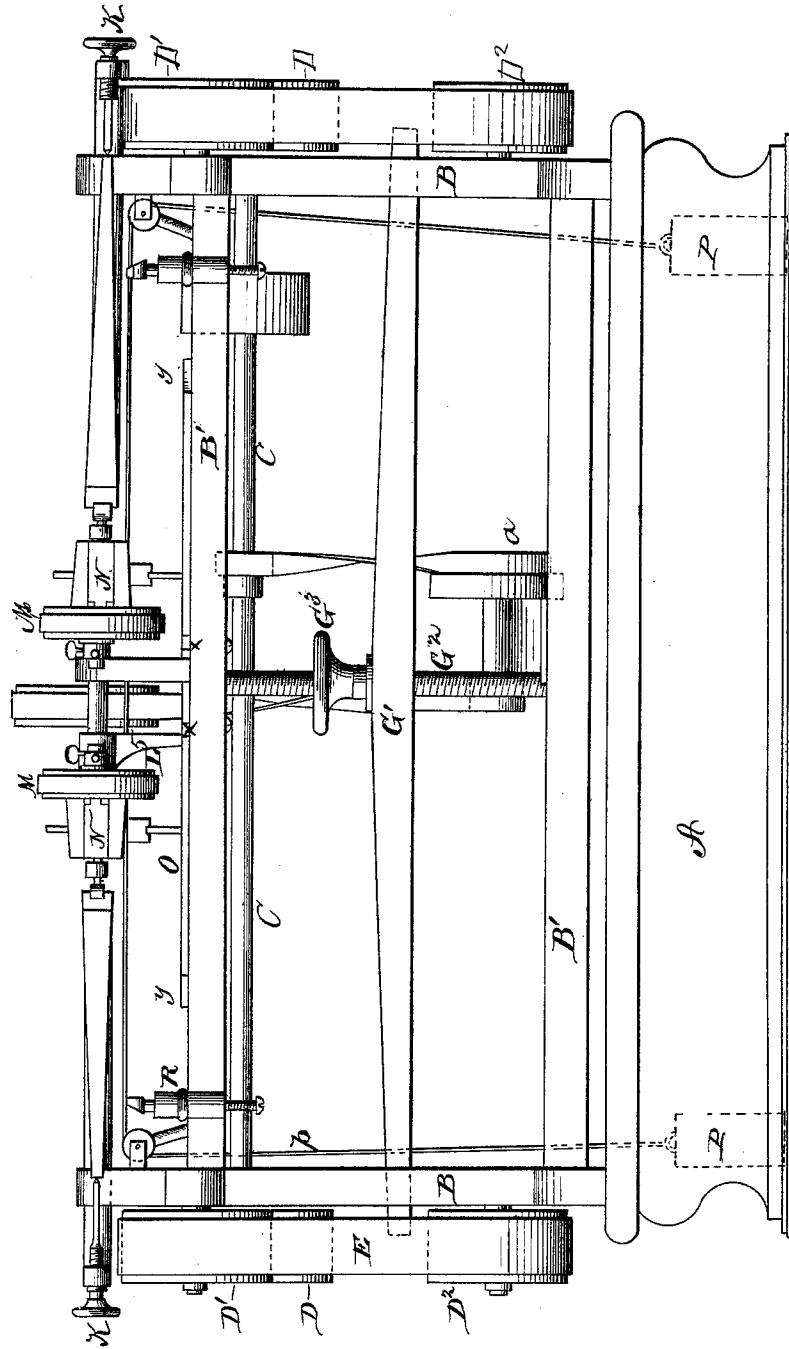

WITNESSES

Frank L. Curand
Kaukhalt

INVENTOR

Oscar Allen
Alexander Mason
ATTORNEYS

O. ALLEN.
SPOKE-POLISHING MACHINES.

No. 195,555.

Patented Sept. 25, 1877.

Fig. 2.

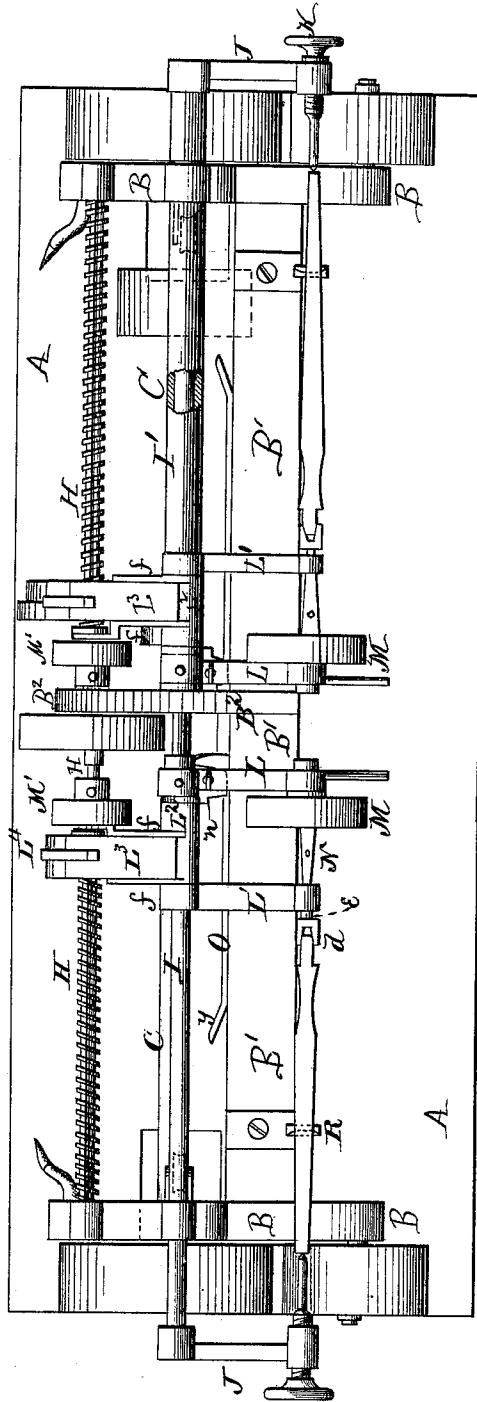

WITNESSES
Frank L. Outland
Frank Galt

INVENTOR
Oscar Allen
Alexander Watson

ATTORNEYS

O. ALLEN.
SPOKE-POLISHING MACHINES.

No. 195,555.

Patented Sept. 25, 1877.

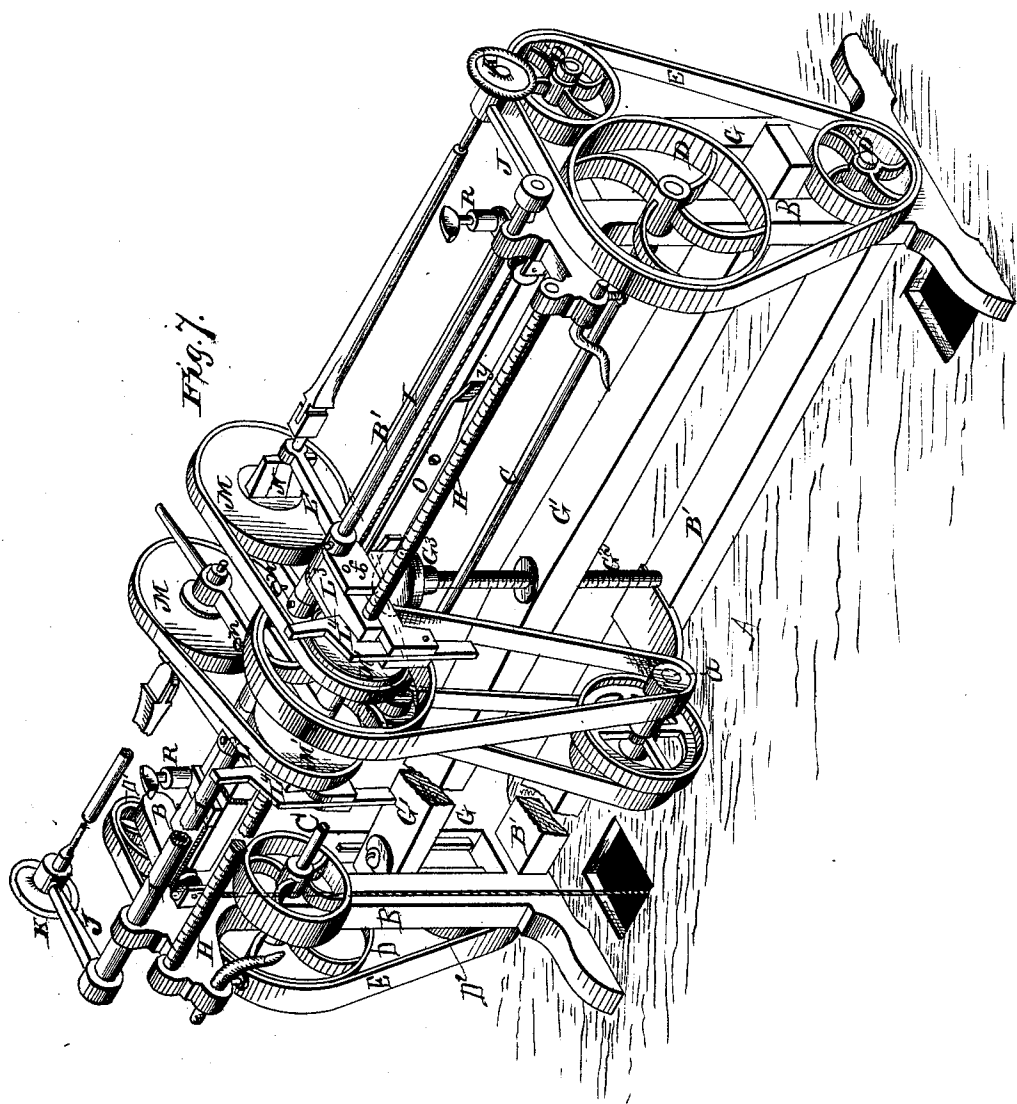

WITNESSES
Frank L. Curran
Henry N. Miller

INVENTOR
Oscar Allen
Alexander Mason
ATTORNEYS

UNITED STATES PATENT OFFICE.

OSCAR ALLEN, OF MOUNT MORRIS, NEW YORK.

IMPROVEMENT IN SPOKE-POLISHING MACHINES.

Specification forming part of Letters Patent No. 195,555, dated September 25, 1877; application filed August 10, 1877.

To all whom it may concern:

Be it known that I, OSCAR ALLEN, of Mount Morris, in the county of Livingston, and in the State of New York, have invented certain new and useful Improvements in Machine for Finishing Spokes; and do hereby declare that the following is a full, clear, and exact description thereof, reference being had to the accompanying drawings, and to the letters of reference marked thereon, making a part of this specification.

The nature of my invention consists in the construction and arrangement of a machine for finishing spokes after being turned in a lathe, as will be hereinafter more fully set forth.

In order to enable others skilled in the art to which my invention appertains to make and use the same, I will now proceed to describe its construction and operation, referring to the annexed drawings, in which—

Figure 1 is a front elevation of my machine. Fig. 2 is a plan view, and Fig. 3 a transverse vertical section, of the same. Figs. 4, 5, and 6 are details. Fig. 7 is a perspective view of the complete machine.

A represents the base upon which the machine is erected. The frame of the machine consists of two end pieces, B B, connected by two longitudinal bars, B¹ B¹. C is a counter-shaft, having its bearings in the end pieces B B, and provided on each end with a pulley, D, around which is placed a quartz-belt, E, said belt passing around another pulley, D¹, so arranged as to make the top of the belt horizontal. The belt also passes around a pulley, D², at the bottom of the end piece. This latter pulley D² is mounted on a stud projecting from a slide, G, placed in a vertical slot in the end pieces B. On top of the two slides or sliding boxes G G is placed a bar, G¹, through the center of which is passed a vertical screw, G², having its bearings in the bars B¹ B¹, and upon said screw is a nut, G³, which, by being screwed down, causes the bar G¹ to press on the boxes G G, forcing the same downward to tighten the belts E E.

H represents a right and left hand screw-shaft, which has its bearings in the side pieces B B, and has also a center bearing in an arm, B², projecting from the top bar B¹, as shown.

Motion is communicated from the engine to the counter-shaft C, from this shaft to a short shaft, a, and from this latter to the screw-shaft H, all by suitable belts and pulleys.

In front of the screw H is a rod, I, placed in suitable bearings, and movable laterally therein. On one end of this rod is placed a tube or sleeve, I', passing through the bearings on that side of the center arm B², and also movable in said bearings.

On each side of this center arm the mechanism is precisely the same, that on one side being attached to the rod I, while that on the other side is attached to the sleeve I'.

On the outer end of the rod I or sleeve I' is secured an arm, J, through the front end of which is passed a centering-screw, K. A suitable distance inward from this arm are fastened two arms, L L¹, by means of set-screws b b. Between these arms is placed the pulley M, to which the facer N is attached, and through the center of said facer and pulley is passed a shaft, e, with a crotch, d, at its inner end, to receive the tenon of the spoke, the other end of the spoke being held by the centering-screw K.

The shaft of the crotch d may be drawn out and in, as required, to suit long or short spokes, and the shaft held by a pin through the facer.

The facer N is provided with removable corner-pieces h h, fastened with screws i, so as to be altered for finishing any size or style of spoke.

Between the arms L L¹ on the rod I or sleeve I' is a sleeve, L², forming two flanges, f f, on its rear side, between which are pivoted two arms, L³ L³, with a spring, k, so arranged between them as to throw their outer ends apart.

The outer ends of these arms are so constructed as to form, when closed together, a nut around the screw-shaft H. L⁴ is a latch for holding said arms closed.

The pulley M is, by a belt, connected with a pulley, M', feathered on the screw-shaft H, the feather-groove in said shaft extending the entire length thereof, and said pulley M' held in a fork in one of the flanges f.

The arm L is extended forward, forming a handle for holding the spoke down against the polishing-belt, and below said arm is an-

other arm, L^5 , also hinged on the rod I or the sleeve I' . From this arm L^5 projects a lug, m , against which a regulating set-screw, n , through the arm L , bears, to regulate the depth at which the spoke is to be depressed. The end of the arm L^5 , at the commencement of the outward movement, passes through an inclined slot, x , in a track, O , and is held against the rear side thereof by the tension of a cord, p , attached to the arm L or L^1 , and passing to the other end of the machine over a pulley, and with a weight, P , suspended from it. At the outer end of the track O is an incline, y , over which said arm L^5 rides, and when it passes the same it is thrown forward to the front of the track, raising the spoke from the quartz-belt.

It will be seen that there are two sets of holders for spokes, with their appropriate mechanisms operating from the center outward toward both ends, the movement of the two sets being simultaneous, and coinciding exactly.

The nuts being thrown in connection with the screw-shaft, said screw moves the two sets outward, at the same time rotating the spokes, which are held against the quartz-belts for being finished. At the same time as the arm L^5 is thrown in front of the track O , as above described, the facer N strikes on an adjustable rest, R , whereby the facer is thrown over the corner, and is dropped on the flat part of the spoke. As this movement is completed, or, in other words, simultaneously therewith, the latch L^4 strikes against a stop, S , and is released from the arms L^3 L^2 , which thus open by the action of the spring k between them, and the weight P at once returns the holder to the center of the machine, where the spoke is removed and another inserted.

Having thus fully described my invention, what I claim as new, and desire to secure by Letters Patent, is—

1. In a machine for finishing spokes, two sets of holders, operated simultaneously in opposite directions by a right and left hand screw-shaft, substantially as herein set forth.

2. The combination of two sets of spoke-holders, a right and left hand screw-shaft for operating the same in opposite directions, and two endless rotating quartz-belts, substantially as and for the purposes herein set forth.

3. In a machine for finishing spokes, the combination of two endless rotating quartz-belts, two tightening-pulleys mounted on studs projecting from vertically-movable slides, a single pressure-bar, and a stationary center-screw with nut, whereby the two belts are adjusted simultaneously to the same tension, as herein set forth.

4. The combination of the two sets of spoke-holders, the laterally-movable rod, and the laterally-movable sleeve on said rod, as and for the purposes herein set forth.

5. The combination of the facer N with removable corner-pieces h h , pulley M , and shaft e , with crotch d , substantially as herein set forth.

6. The combination, with the spoke-holder, of the sleeve L^2 with flanges f f , the arms L^3 L^2 , with interposed spring k , screw H , latch L^4 , and stop S , substantially as and for the purposes herein set forth.

7. The combination, with the spoke-holder, of the arm L^5 , with lug m , the set-screw n , track O , with slot x and incline y , and the cord p , with weight P , substantially as and for the purposes herein set forth.

In testimony that I claim the foregoing I have hereunto set my hand and seal this 2d day of July, 1877.

OSCAR ALLEN. [L. s.]

Witnesses:

GEO. C. BRANCH,
A. M. CARTHER.